

norco

DESCRIPTION
POWER TRAIN LIFT TABLE

CAPACITY
2500 LBS.

MODEL NO.
72850

REPLACEMENT
PARTS

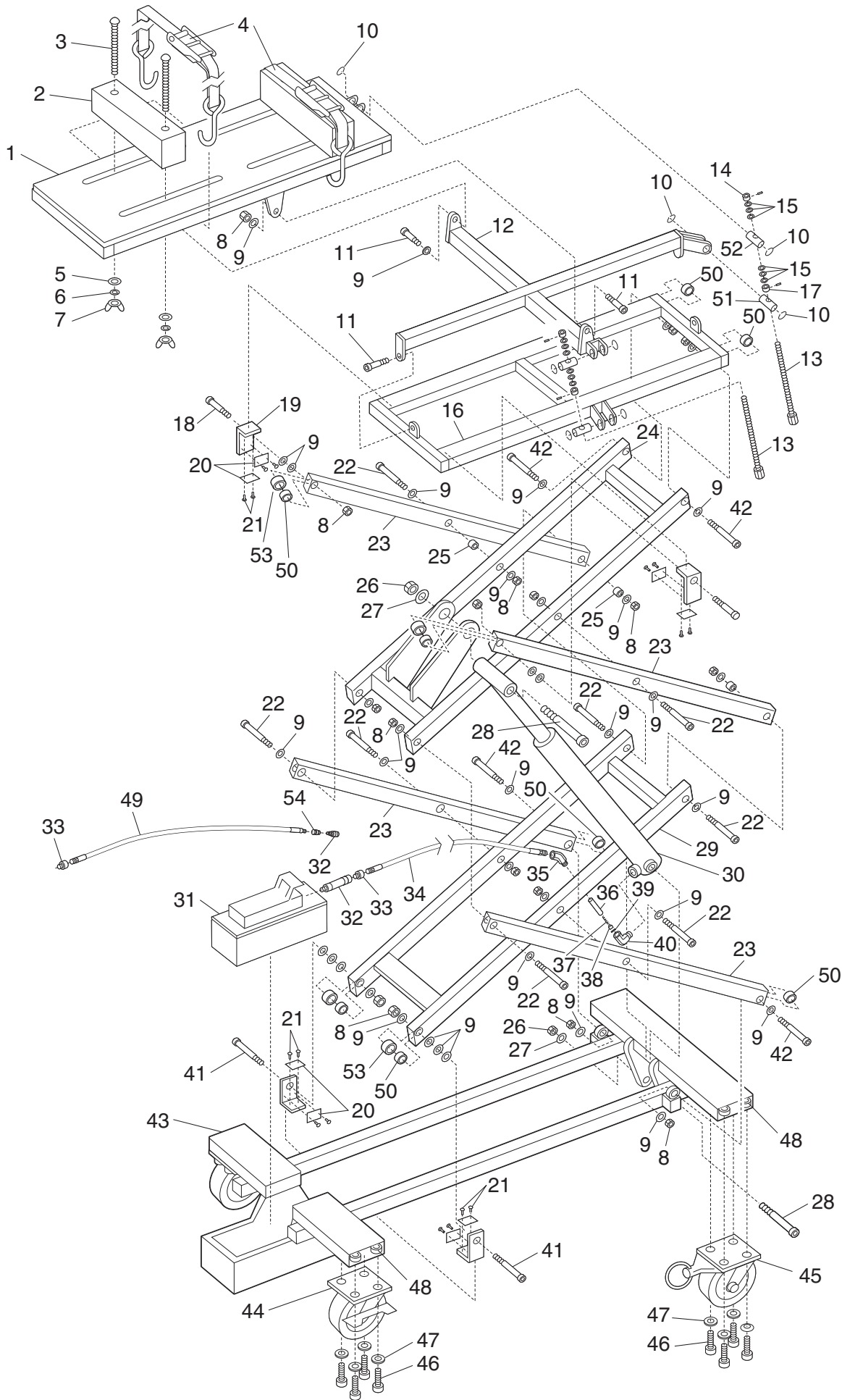

INDEX NO.	DESCRIPTION	PART NO.	REQ'D NO.
1	Saddle Assembly	284065	1
2	Wood Block	284068	2
3	1/2" Carriage Bolt	11213	4
4	Ratchet Tie Down	72002	1 pr.
5	1/2" Flat Washer	2113	4
6	1/2" Lockwasher	2001	4
7	1/2" - 13 Wing Nut	1069	4
8	5/8" - 11 Nyloc Nut	1098	20
9	3/4" SAE Flat Washer	2137	24
10	Trunion Retaining Rings	12141	8
11	3/4" Dia. x 1 1/4" Long Shoulder Bolt	11231	4
12	Saddle Base Assembly	284070	1
13	Drive Screw Assembly	284089	2
14	Collar with Set Screw	229081	2
15	Bearing and Two Races	229085	4 sets
16	Support Table Assembly	284075	1
17	Collar with Set Screw	284087	2
18	3/4" Dia. x 2 1/2" Long Shoulder Bolt	11219	2
19	Guide Angle	284084	4
20	Guide Plate	284086	8
21	1/4" - 20 x 1/2" Flat Allen Socket Cap Screw	3177	16
22	3/4" Dia. x 4 1/4" Long Shoulder Bolt	11221	8
23	Scissor Arm Assembly	284095	4
24	Top Lift Frame Assembly	284080	1
25	Bronze Oilite Bushing 2" Long	284116	8
26	3/4" - 10 Nyloc Nut	1097	2
27	1" Flat Washer	2138	2
28	1" Dia. x 4" Long Shoulder Bolt	11222	2
29	Bottom Lift Frame Assembly	284085	1
30	Cylinder	284105	1
31	Air/Hydraulic Pump	910130	1
32	Ram Half Coupler	910231B	2
33	Hose Half Coupler	910232B	2
34	Hose Assembly	284110	1
35	45° Street Elbow	13026	1
36	Velocity Fuse Body	284121	1
37	Velocity Fuse Spring	793366	1
38	Velocity Fuse Valve	793364	1
39	Retaining Pin 1/16" Dia. x 1/2" Long	11233	1
40	90° Street Elbow	13011	1
41	3/4" Dia. x 2 3/4" Long Shoulder Bolt	11232	2
42	3/4" Dia. x 2 1/4" Long Shoulder Bolt	11234	4
43	Base Frame Assembly	284100	1
44	Locking Caster Wheel	284125	2
45	Directional Locking Caster Wheel	284120	2
46	3/8" - 16 x 1 1/4" Long Hex. Hd., Gr. 5 Bolt	11013	16
47	3/8" Flat Washer	2108	16
48	3/8" - 16 Nyloc Nut	1054	16
49	60" Extension Hose	284130	1
50	Bronze Oilite Bushing 1" Long	284111	8
51	Drive Trunion	284118	2
52	Slave Trunion	284119	2
53	Roller Bushing	284088	4
54	Female Pipe Coupler	13039	1